

**ITM STEMS & HANDLEBAR USER MANUAL –
THE CORRECT ASSEMBLING OF ITM STEMS & HANDLEBAR**

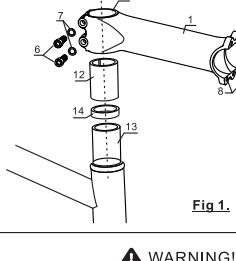

Fig. 1.

⚠ WARNING!
Read the following instructions for the correct use of the ITM headset stem and handlebar. These instructions and any update are available for download at www.itm.it

⚠ WARNING!
Riding a bicycle can be and often really is extremely dangerous. Even though the ITM headset stem and handlebar has been designed and manufactured using the most advanced technology and materials, the poor state of many roads, the cyclist's speed at the moment of impact, hazardous climatic conditions, the cyclist's weight and his steering skills are only some of the factors that contribute to the possible and indeed foreseeable impact energies, factors which lie outside the capacities of the ITM headset stem and handlebar. No stem, including ITM headset stem and handlebar can support ALL the possible impact factors. The ITM handlebar and stem exceeds the requirements of European standard EN 14781 – EN 14766 – EN 14764. Keep this manual and all the documentation supplied by ITM as it contains important information.

NOTE:
ITM RESERVES THE RIGHT TO MODIFY THIS USER'S MANUAL. ANY SUCH MODIFICATION WILL BE REPORTED ON THE ITM INTERNET SITE (www.itm.it) AND/OR MAY BE OBTAINED BY CONTACTING ITM AND/OR YOUR OWN AUTHORIZED ITM DEALER. CHECK OUT THESE THREE SOURCES OF INFORMATION PERIODICALLY TO SEE IF CHANGES HAVE BEEN MADE TO THIS USER'S MANUAL.

NOTICES TO READ WITH EXTREME CARE

⚠ WARNING!
Carefully check every bike component, paying particular attention to the handlebar and stem before every outing. Check that there are no breakages or deformations. If you find any, do not use the bicycle. Contact a professional mechanic for all the repairs/replacements necessary.

⚠ WARNING!
Get your mechanic to check the ITM handlebar and stem regularly. The experience acquired by ITM shows that a great many accidents can be avoided easily by carrying out preliminary checks on components by a professional mechanic.

⚠ WARNING!
Given the product material type, check that it is still intact after impacts or falls and replace it immediately if damage is noticed.

⚠ WARNING!
ITM declines all responsibility for injuries and/or damage caused by failure to replace damaged diately components promptly.

⚠ WARNING!
ITM declines all responsibility for injuries and/or damage caused by failure to scrupulously observe the instructions regarding bolt tightness. A different bolt tightness can affect and indeed affects the intactness of the ITM handlebar and stem.

Technical description

- The ITM handlebar and stems are super-lightweight professional stemsfar AS type forksteerers.
- Headset set: Ø 28,6 and 25,4 mm with and without reduction bushings (provided).
- Hole for handlebar: Ø 31,8 and 25,4 mm.
- Extensions: 70 – 80 – 90 – 100 – 110 – 120 – 130 – 140 mm.
- Spacer rings, optional, to adjust the handlebar height to the cyclists needs, available in thicknesses 3 – 5 – 10 – 20 mm.
- Design by ITM finishing as anodized or coated.

Assembling the components

⚠ WARNING!
The ITM headset stem is a hi-tech product and, therefore, must be assembled exclusively by a specialized mechanic using professional tools. DO NOT ATTEMPT TO FIT THE ITM HANDLEBAR AND STEM ON YOUR OWN.

⚠ WARNING!
If you decide not to follow our recommendation, comply scrupulously with these instructions and be aware that you do so exclusively at your own risk and peril.

⚠ WARNING!
Tighten the bolts to the torque value indicated. Always use a torque wrench.

ITM declines all responsibility in the event of operations not carried out in compliance with these instructions. It is important to comply with the indicated torque values because other values may irretrievably deform the various components or damage the bolts or the component itself, and compromise its integrity.

ASSEMBLING THE AHEADSET STEM IN THE FORK STEERER.

If you use a fork with a carbon fibre steerer use the special anti-crushing devices (to insert inside the steerer) that can be found on the market or provided with the fork itself or a ITM expander. We recommend the expander must have an appropriate length, well longer than the stem clamping area.

Sand the hole 11 of the headset stem (fig. 1) with fine-grain emery cloth and then clean carefully using methylated spirit.

Clean and degrease the fork steerer (fig. 1) carefully using methylated spirit.

Slacken the bolts 6 (fig. 1).

Insert any compensator rings 14 (ITM option) into the fork steerer 13.

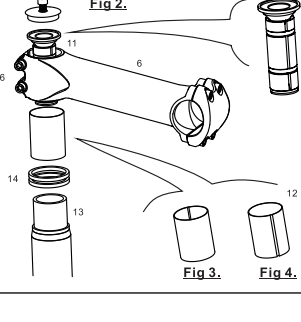

In the case of Ø 25,4 fork steerers, insert the reduction bushing 12 into the headset stem. In the case of forks with a metal steer, take care to position the vertical cut in the bushing towards the rear split in the headset stem (fig. 3).

For forks with carbon fibre steerers, position the bushing with the split turned towards the side opposite the slit in the clamp (fig. 4).

Insert the headset stem on the fork steerer as shown in figures 2 and 5.

The distance G between the outside top part of the handlebar 1 and the inner top part of the fork steerer 13 must not exceed 5 mm. (fig. 5).

Centre the headset stem so that it is coaxial with the bicycle centreline.

Screw in the bolt 9 with the washer 10 until the play of the headset barings has been eliminated completely (the bolt 9 and washer 10 are part of the headset).

Block the bolts 6 slightly, and then centre and orient the headset stem in the most suitable position.

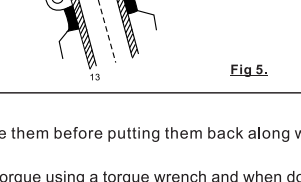

If you have to remove the bolts 6 completely, grease them before putting them back along with the washers 7.

Completely tighten the locking bolt 6 to the indicated torque using a torque wrench and when doing be sure to alternate the locking of them at one turn per time.

⚠ WARNING!
It is important to respect the torque values shown on the stem. Always use a torque wrench. ITM declines all responsibility for tightening not carried out as described in these instructions. It is important to respect the values given because different torque values can deform the fork steerer, especially if it is made of carbon fibre, and cause damage to the bolts and the headset stem itself as a consequence.

FITTING THE HANDLEBAR ON THE AHEADSET STEM

Clean and grease the hole 8 (fig. 1) and the middle part of the handlebar carefully using normal solvents available on the market (preferably methylated spirits).

Unscrew the handlebar on the seat of the headset stem 1 (fig. 6).

Rest the plate 2 on the handlebar.

Ensure that the space between the headset stem and the plate is equal both at the top E and bottom F (fig. 7).

Slide the bolts 3 and 4, with the washer 5, by hand.

Screw in the bolts 3 and 4 alternately without securing them.

Centre and orient the handlebar in the most appropriate position.

Alternatively screw in the bolts 3 and 4 until they are tightened, ensuring to alternate the blocking up and down and at one turn at time.

ALWAYS USE A TORQUE WRENCH

Ensure that the space between the headset stem and the plate is equal both at the top and bottom (E = F).

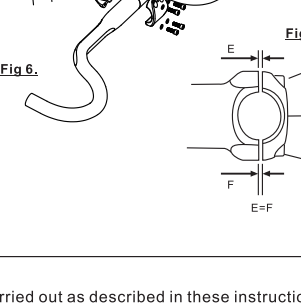

ITM declines all responsibility for fastenings not carried out as described in these instructions. It is important to comply with the values given because other torques can deform the handlebar and, as a consequence, cause damage to the bolts and to the headset stem itself and affect their integrity.

Cleaning maintenance

Periodically wash the headset stem thoroughly using detergents available on the market that do not contain abrasives or solvents.

If you have to remove the bolts, we recommend greasing the threaded section with neutral grease before putting them back. If they are dirty, you must wash them using a grease removal product before greasing them.

Do not use bolts different from those provided.

When the ITM handlebar headset stem is of no further use never dispose of it in the environment. Dispose of the product in an authorized dump.

NOTE: Ø = diameter of the piece
Nm = Newton metre (bolt tightness torque unit of measurement)

ITM reserves the right to make improvements and changes without notice.

STEM WITH CABLE ROUTING SYSTEM

In case you decide to use stem suitable for the hidden cable support. Here under, you can see the way to do.

The ITM stems suitable for this system are VISIA, VOLO, FX1

Please follow all the necessary safety instruction you found in this file and extra pay attention to : Never modify the cable guide holes! Do not enlarge or use different shape of original delivered part.

The assembly of all the headset must be done by special skilled mechanical person

Position and size must be maintained in order to guaranty the handlebar-rt assembly.

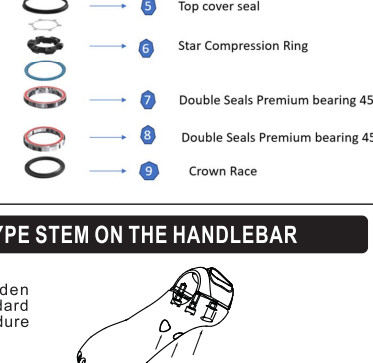
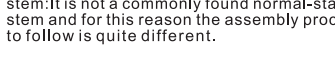

ASSEMBLY OF THE ARIES TYPE STEM ON THE HANDLEBAR

The Aries stem is a special three-screw hidden stem:It is not a commonly found normal-standard stem and for this reason the assembly-procedure to follow is quite different.

⚠ WARNING!
We highly recommend you follow all the instructions provided below carefully.

The main difference is that the ARIES stem has THREE hidden locking screws, which are accessible from below.

To achieve best results, we recommend you connect an extension 9 to the dynamometric wrench so that the dynamometric wrench does not come into contact with the actual stem or handlebar.

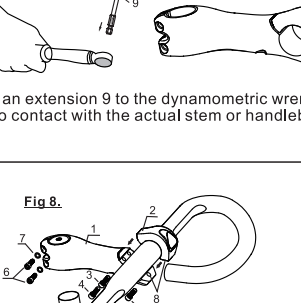

Operations

Use the plate 2 on the curve.

Assure your hands to position the screws 3, 4, and 5, in their holes.

Centre and align the handlebar curve in the desired position.

Tighten screws 3 and 4 as far as possible, then tighten screw 5 leaving a max. space of 2.5mm.

⚠ WARNING!
Do not tighten screws 3, 4 and 5, alternately, but make sure you follow the instructions above when assembling this stem: i.e. tighten screws 3 and 4 as far as possible, only then tighten screw 5 following the indications provided concerning the maximum force applicable using the dynamometer wrench.

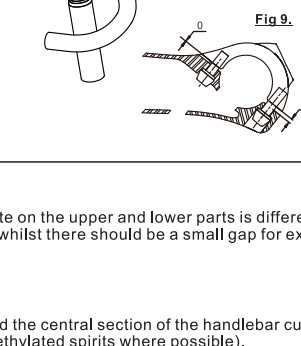

⚠ WARNING!
Check that the space between the stem and the plate on the upper and lower parts is different, i.e. the upper section should be completely closed whilst there should be a small gap for extra tightening in the lower section (Diag.9).

Maintenance

Clean and carefully degrease the hole 8 (Diag.8) and the central section of the handlebar curve using standard solvents available on the market (methylated spirit where possible).

Check the handlebar stem regularly, if you notice any signs of damage, replace the damaged parts immediately.

Replace all screws every two years.

All modifications will lead to cancellation of all warranty rights.

Warranty limits

The final decision to repair or substitute the defective items covered by warranty is on discretion of ITM. It is the user's responsibility to check periodically the product to determine whether it is necessary to contact ITM service center.

Warranty under this warranty must be made through an authorised ITM dealer. **Together with the warranty card, a proof of purchase is require**

Not covered by warranty

- Products modified, not correctly used.
- Products not correctly assembled or repaired.
- Products damaged by the use of other materials or assembled by unskilled personnel.
- Products used in competitions, on acrobatic races or during exhibitions.
- Aesthetical finishes.
- Cost of labour for assembling/disassembling.
- Average wear and tear of time.